

2 PIECES CARBON STEEL BALL VALVE PN63 ATEX DIN M3



WSF
ISO9001

TÜVRheinland®
PED/2014/68/UE

CE



Certificate 3.1

Size : DN 1/4" to 3"
Ends : Threaded BSP
Min Temperature : - 20°C
Max Temperature : + 180°C
Max Pressure : 63 Bars (up to DN 3/4")
Specifications : Anti blow-out stem
Locking device
Full bore

Materials : Carbon steel ASTM A216 WCB

2 PIECES CARBON STEEL BALL VALVE PN63

SPECIFICATIONS :

- Full bore
- Anti blow-out stem
- PTFE packing
- Locking device
- Solid ball
- 2 pieces type
- Black oxyde finish

USE :

- Chemical and pharmaceutical industries, petrochemical industries, hydraulic installation, compressed air
- Min and max Temperature Ts : -20°C to + 180°C
- Max Pressure Ps : 63 bars up to DN3/4", 50 bars from DN 1" to 1"1/4, 40 bars from DN 1"1/2 to 2" , 25 bars from DN 2"1/2 to 3" (see graph)

PRESSURE / TEMPERATURE GRAPH (STEAM EXCLUDED) :

PRESSURE

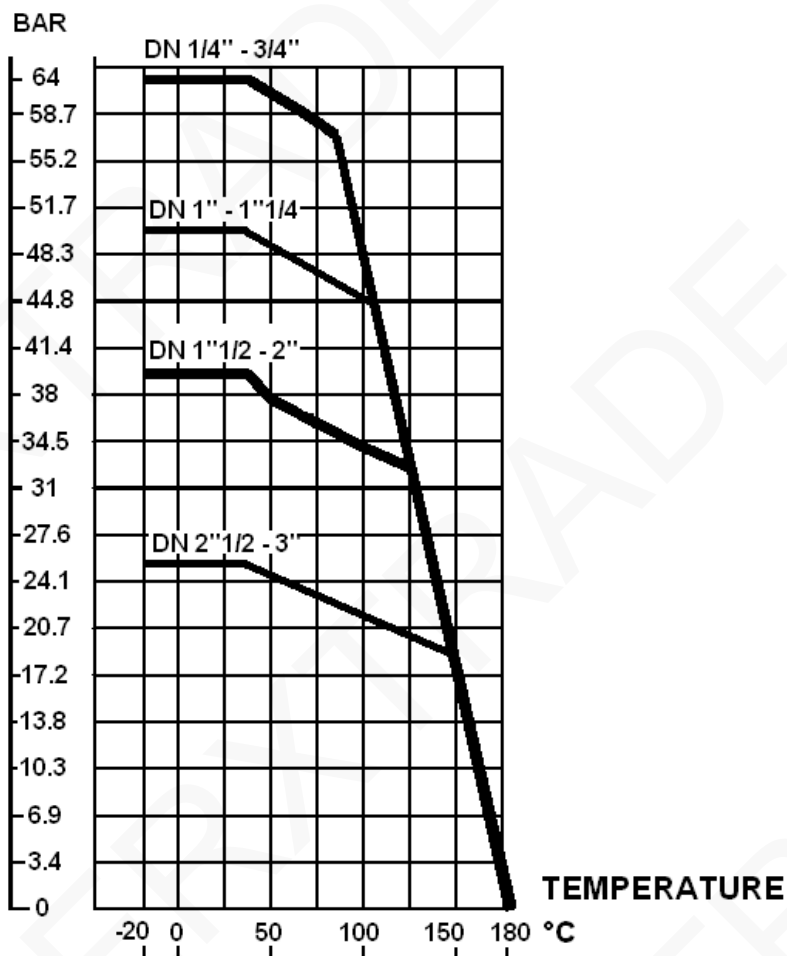

2 PIECES CARBON STEEL BALL VALVE PN63

RANGE :



- Carbon steel body BSP threaded with red handle **Ref. 705** DN 1/4" to DN 3"



- Blue handle cover **Ref. 9830380 to 9830384** DN 1/4" to DN 3"



- S.S. 304 red butterfly handle **Ref. 9831131 to 9831134** DN 1/4" to DN 1"

2 PIECES CARBON STEEL BALL VALVE PN63

MATERIALS :

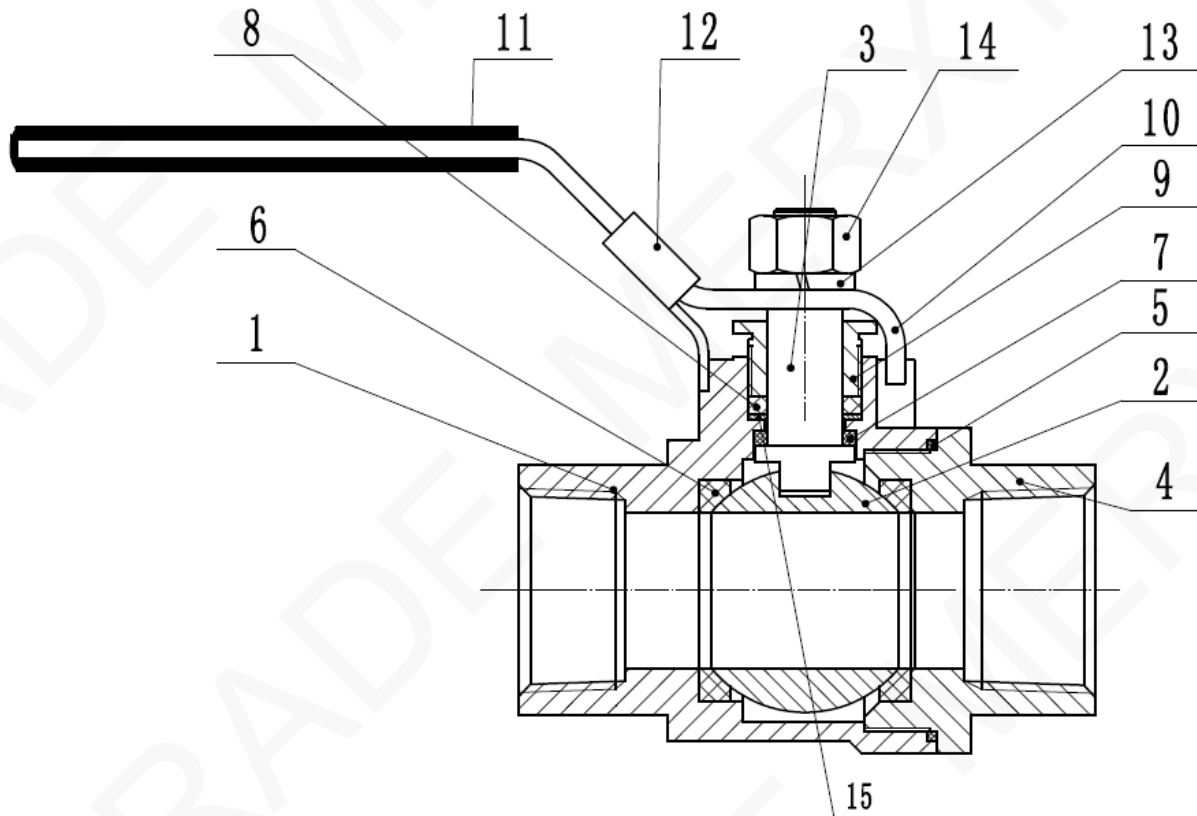

Item	Designation	Materials
1	Body	ASTM A216 WCB
2	Ball	AISI 304
3	Stem	
4	End	ASTM A216 WCB
5	Body gasket	PTFE
6	Seat	PTFE filled with 3% glass fiber
7	Gasket	PTFE
8	Packing	
9	Packing nut	AISI 304
10	Handle	
11	Handle cover	PVC
12	Locking device	AIS 304
13	Washer	
14	Nut	
15	Antistatic device	

2 PIECES CARBON STEEL BALL VALVE PN63

SIZE (in mm) :

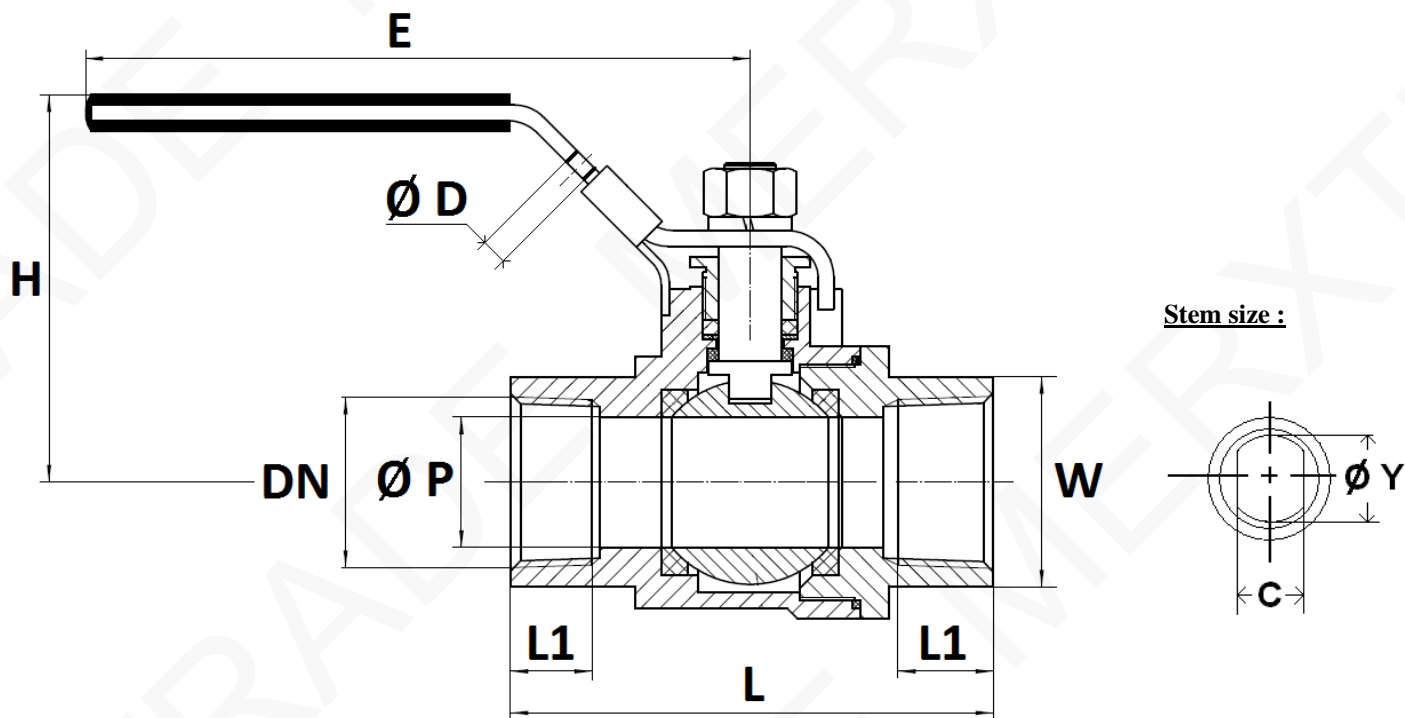

Stem size :

Ref.	DN	1/4"	3/8"	1/2"	3/4"	1"	1"1/4"	1"1/2"	2"	2"1/2"	3"
705	Ø P	9.2	12.5	15	20	25	32	38	50	65	80
	L	50	60	75	80	90	110	120	140	185	205
	Ø D	8	8	8	8	8	8	8	8	8	8
	E	83	83	103	103	151	151	194	194	285	285
	H	49	53	60	62	77	81	91	103	117	127
	L1 (BSP)	10	10.5	13.5	14.5	17.5	19	19	23.5	27	30.5
	W on flat	19	22	26	32	38	50	54	68	85	98
	C	4	5	6.5	6.5	8	8	8.5	8.5	12	12
	Ø Y	6	8	9.5	9.5	11.5	11.5	16	16	20	20
Weight (in Kg)	0.27	0.26	0.32	0.42	0.67	1.12	1.73	2.78	5.78	8.38	

2 PIECES CARBON STEEL BALL VALVE PN63

BUTTERFLY HANDLE SIZE (in mm) :

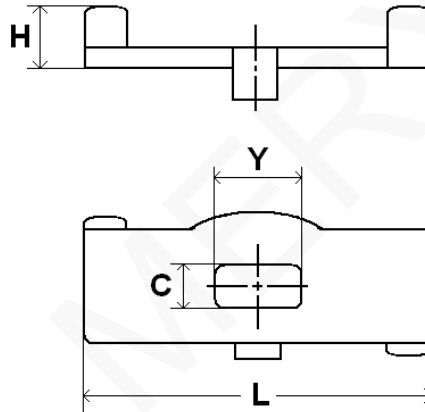

- **Ref. 983113 :**

DN	1/4"	3/8"	1/2"	3/4"	1"
L	55	55	60	60	70
H	20	20	22	22	28
C	4	5	6.5	6.5	8
Y	7	8	9.5	9.5	11.5

TORQUE VALUES (in Nm without safety coefficient) :

DN	1/4"	3/8"	1/2"	3/4"	1"	1"1/4"	1"1/2"	2"	2"1/2"	3"
Torque (Nm)	2.7	2.7	3	4	5	6	8	10	40	60

2 PIECES CARBON STEEL BALL VALVE PN63

STANDARDS :

- Fabrication according to ISO 9001 : 2015
- DIRECTIVE 2014/68/EU : CE N° 0035
Risk category III Module H
- Certificate 3.1 on request
- Pressure Tests according to ISO 5208, Rate A
- Threaded ends BSP cylindrical according to ISO 228-1
- Length according to EN 16722 Series M3 (DIN 3202 M3)
- ATEX Group II Category 2 G/2Dc T3 Zone 1 & 21 Zone 2 & 22 (optional marking)

ADVICE : Our opinion and our advice are not guaranteed and MXT shall not be liable for the consequences of damages. The customer must check the right choice of the products with the real service conditions.

INSTALLATION AND MAINTENANCE

BEFORE INSTALLATION :

Pipe-line must be cleaned and free from residual of weldings, rubbish, shaving and every kind of extraneous materials. Pipe-line must be perfectly aligned and their support properly dimensioned so that there's no external constraint.

Please use the right product according to the services conditions to seal the valve.
Use the right bolt tightening so that the ends won't be damaged.

CLEANING AND TESTS

Keep opened the valves during the cleaning operation so that there are no impurities between the ball and the body.

Tests under pressure must be done with a cleaned pipe-line.

Open partially the valve for tests. Pressure test do not exceed the valve specifications according to ISO 5208.

MAINTENANCE

It's recommended to operate the valve twice (open and close) 1 to 2 times per year.

When intervention on the valve, be sure there's no pressure in the pipe-line, there's no fluid in it, and that it is isolated.
The temperature must be low enough to operate without risks.
If there's a corrosive fluid, inert installation before intervention.

When the valve is under pressure :

If there's a leakage at the packing, tighten it slightly so that the leakage disappears.